

glazing

NOTES
 1. All work to be done in accordance with the specifications and drawings.
 2. All materials to be used shall be of the highest quality and shall be approved by the Architect.
 3. The Contractor shall be responsible for obtaining all necessary permits and approvals.

PROPOSED WORKS NOTES

- ① New composite shop front door to be fitted with double glazing units. The door will have a letter plate in the mid-rail. Allow for fan-light above the door as shown.
- ② Reinstate existing refurbished linoleum windows. Allow for making good all round.
- ③ New aluminum rainwater down pipes and gutters to be installed as shown.

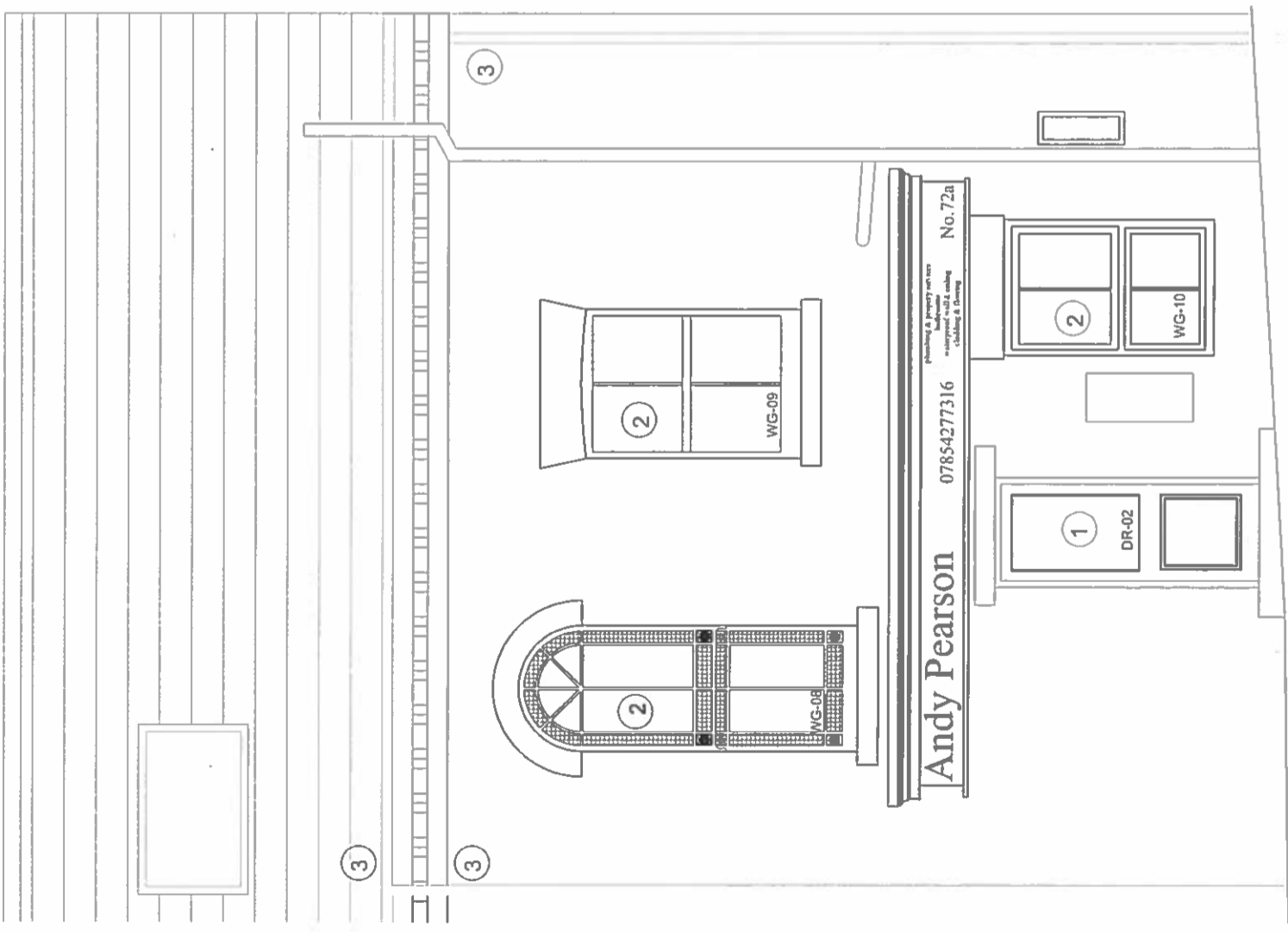

72A High Street - Proposed Elevation

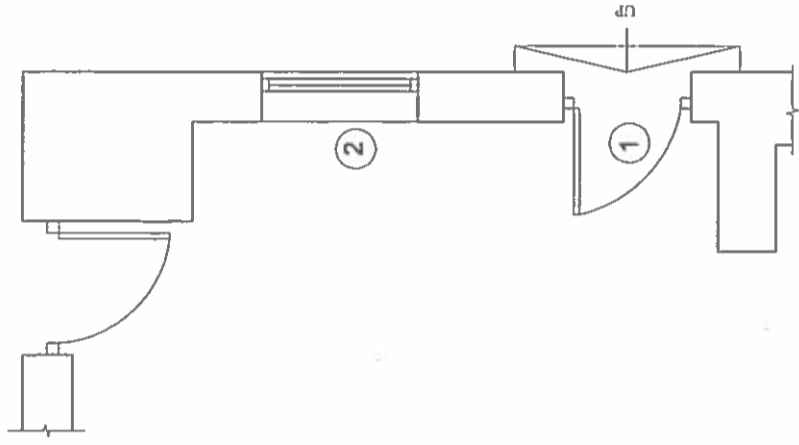

72A High Street - Proposed Plan

NO.	REV.	DATE	BY	DESCRIPTION
1	1	15/01/2024	AS	ISSUED FOR TENDER
2	1	15/01/2024	AS	ISSUED FOR TENDER
3	1	15/01/2024	AS	ISSUED FOR TENDER
4	1	15/01/2024	AS	ISSUED FOR TENDER
5	1	15/01/2024	AS	ISSUED FOR TENDER

harrisirwin
 architects & designers
 111 High Street, Edinburgh, Midlothian, EH1 1JG
 Tel: 0131 225 1111
 Email: info@harrisirwin.co.uk
 www.harrisirwin.co.uk

Project:
 72A High Street Regeneration
 72A High Street
 Edinburgh, Midlothian, EH1 1JG

Client:
 go
 Glasgow City Council
 Regeneration and Development

Drawing Title:
 72A Proposed Works Plan and Elevation

Scale:
 1:50

FOR TENDER

2024 - 01 - 15
 2024 - 01 - 15

NOTE
 Make good all round with materials suitable for the application.
 THIS DRAWING IS TO BE READ IN CONJUNCTION WITH THE PRE CONSTRUCTION INFORMATION PACK